

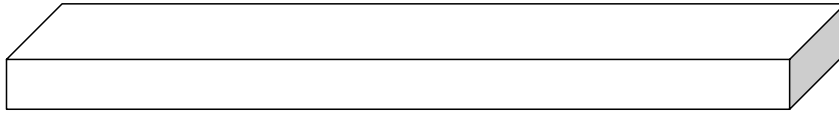

Modular Short Bench Top
M-107 48 lbs
32.00"L x 17.00"W x 4.00"H

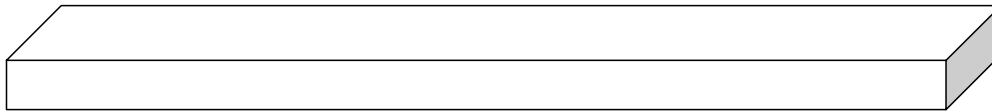

Modular Medium Bench Top
M-108 238 lbs
40.00"L x 17.00"W x 4.00"H



Modular Long Bench Top
M-109 283 lbs
48.00"L x 17.00"W x 4.00"H

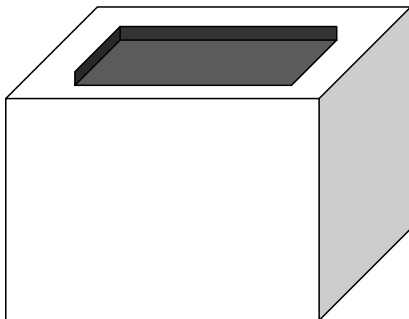

Modular Planter
M-100 217 lbs
17.00"W x 15.00"H

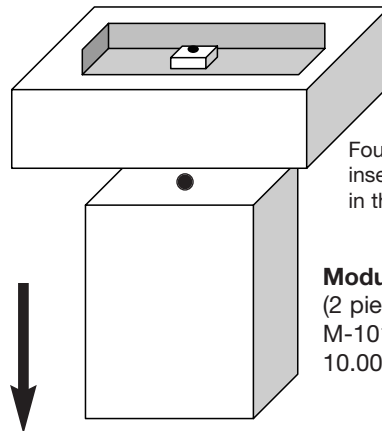

Fountain Assembly can be inserted into any planter in this series.

Modular Fountain Insert
(2 pieces)
M-101 47 lbs
10.00"W x 13.00"H

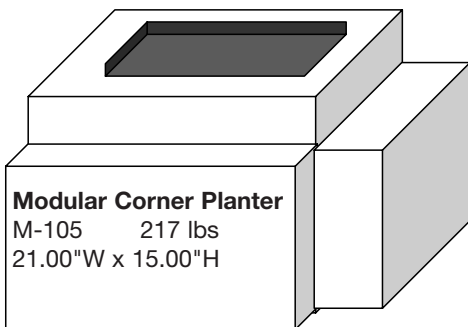

Modular Corner Planter
M-105 217 lbs
21.00"W x 15.00"H

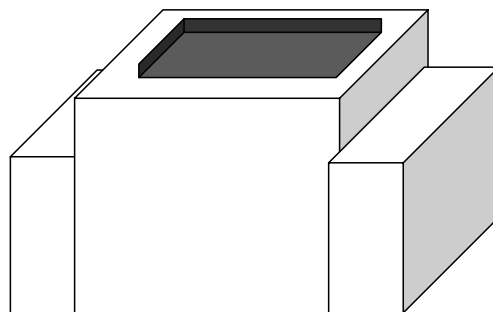

Modular Center Planter
M-103 339 lbs
25.25"L x 17.00"W x 15.00"H

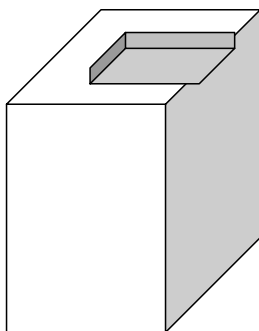

Modular Leg
M-102 339 lbs
17.25"L x 9.5"W x 11.00"H

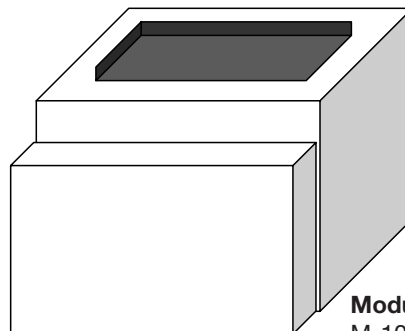

Modular End Planter
M-104 277 lbs
21.25"L x 17.00"W x 15.00"H